

FAIL-SAFE 'MIL-SPEC'

Model: SF100 - M10

SNAP-FLAT™

The Safe Over-Center Latch

New 'Ruggedized' Military Specified Version:

- **Silent** - No 'metal to metal' interface between base and Handle
- **Durable** - Military Grade 'e-coat' over all 316 stainless steel components
- **Low Profile** - with completely protected springs
- **Easy to install** - Bolt-on or Rivet

BENEFITS OF THE SNAP-FLAT LATCH



FAIL-SAFE ENGAGEMENT

The design prevents the latch from accidentally disengaging from the hook, even if it hasn't been secured into the over-center position.



REDUCE LATCH DAMAGE

Reduce latch being damaged by securing the latch and handle in the flat position so it doesn't "snag" against other objects.



STRENGTH & DURABILITY

Intelligent design and stainless-steel manufacture to ensure strength, long term reliability and durability.



SAFETY

Prevents injury by securing the latch and handle in the flat position so it can't "gouge" people.



LOCKABLE

Secure your goods with holes allowing for both small and large padlocks.



EASY TO USE

Designed for comfortable, easy release & engagement of the latch. Adjustable length.

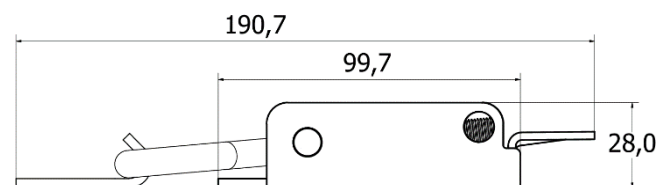
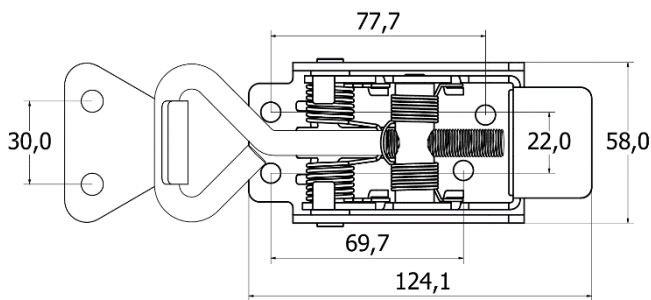

Model: SF100 - M10

**PATENT
PENDING**

